

SLUICE GATE - SPS TL/RTL NPS 8-24

AREA OF USE: Sewer and stormwater, industrial facilities, process water and for the fishing and agricultural industry. SPS-TL/RTL is sealed from the mounting side.

ADVANTAGES WITH WAGATE SPS-TL/RTL:

- Self-supporting frame pre-assembled and ready for operation for bolting onto a wall
- Lip O-ring seal mounted in PEHD for easy replacement. Manually operated damper that can be held in the open position
- Square or circular opening with the option for a tight pipe connection to the damper. Can be manufactured with a rounded flange for installation in a chamber



VARIANT: SPS-RTL with welded pipe for wall penetration and in chamber installation

MATERIAL:

Frame	EN 1.4404 & PEHD
Damper plate	EN 1.4404 (EN 1.4462)
Seal against the damper plate	EPDM
Seal against the wall	EPEM sponge rubber

TECHNICAL DATA:

Sealing according to	DIN 19569-4
----------------------	-------------

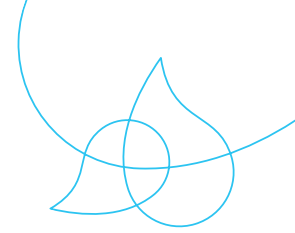

SLUICE GATE - SPS TL/RTL NPS 8-24

SPS-RTL

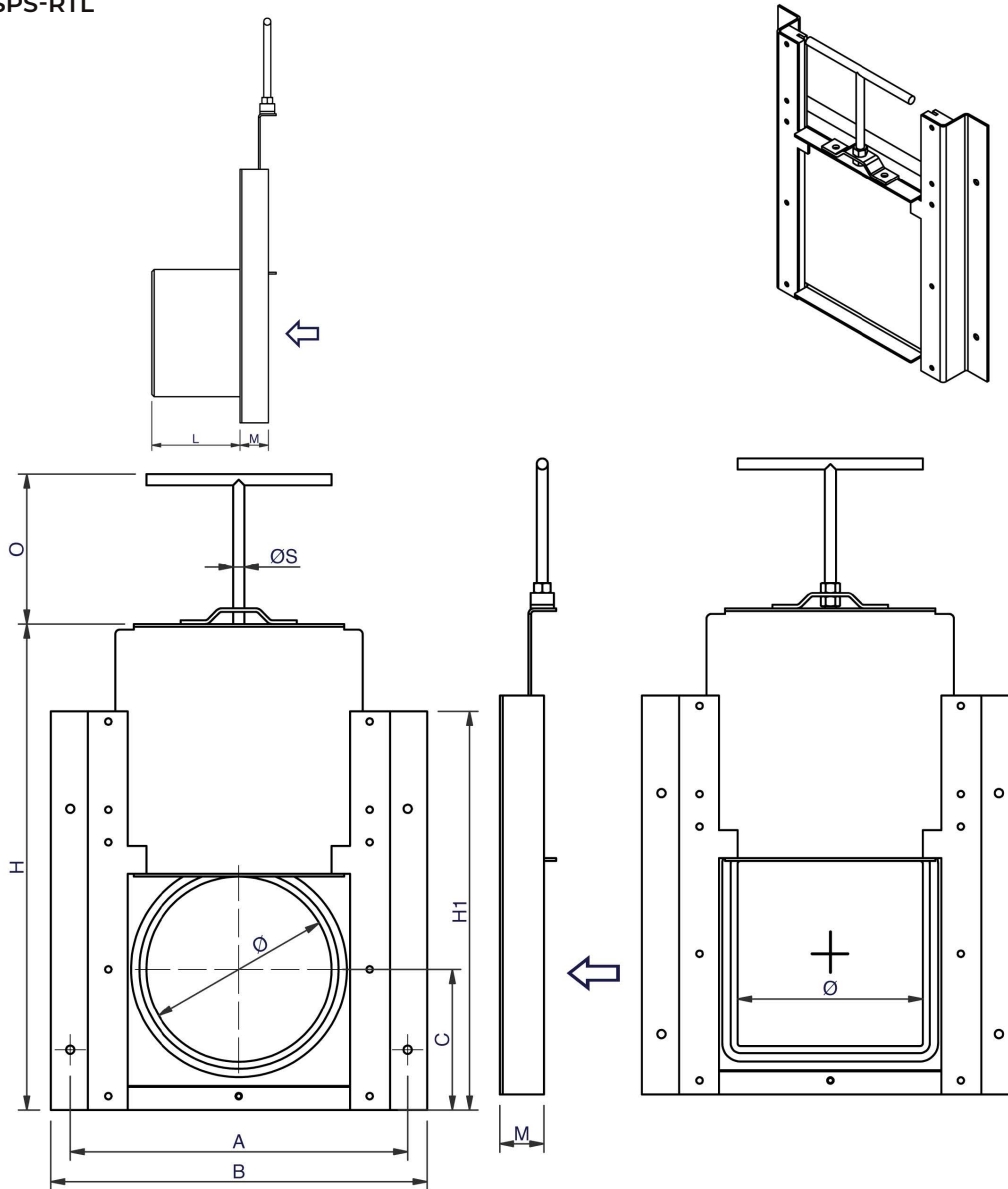

DIMENSIONS IN [INCHES]

NPS	Ø	D	A	B	C	H	H1	L	M	O	ØS	WEIGHT [LBS]	MWC
8	8	8x8	14,33	15,98	5,98	20,63	17,09	> 6,89	1,9	5,91	0,47	17,6	4
10	10	10x10	16,30	17,95	6,97	24,57	19,06	> 7,87	1,9	5,91	0,47	22,0	4
12	14	14x14	18,86	20,51	8,27	29,69	21,65	> 9,84	1,9	5,91	0,47	26,5	4
16	16	16x16	22,20	23,86	9,92	36,38	24,96	> 11,81	1,9	7,87	0,63	35,3	4
20	20	20x20	26,14	27,80	11,89	44,25	28,82	> 14,76	1,9	7,87	0,63	46,3	2
24	25	25x25	31,26	32,91	14,37	54,49	33,86	> 18,70	1,9	7,87	0,63	59,5	2

Other dimensions on request. Reserves the right to changes.