

SLUICE GATE - SPS TL/RTL DN 200-630

AREA OF USE: Sewer and stormwater, industrial facilities, process water and for the fishing and agricultural industry. SPS-TL/RTL is sealed from the mounting side.

ADVANTAGES WITH WAGATE SPS-TL/RTL:

- Self-supporting frame pre-assembled and ready for operation for bolting onto a wall
- Lip O-ring seal mounted in PEHD for easy replacement. Manually operated damper that can be held in the open position
- Square or circular opening with the option for a tight pipe connection to the damper. Can be manufactured with a rounded flange for installation in a chamber



VARIANT: SPS-RTL with welded pipe for wall penetration and in chamber installation

MATERIAL:

Frame	EN 1.4404 & PEHD
Damper plate	EN 1.4404 (EN 1.4462)
Seal against the damper plate	EPDM
Seal against the wall	EPEM sponge rubber

TECHNICAL DATA:

Sealing according to	DIN 19569-4
----------------------	-------------

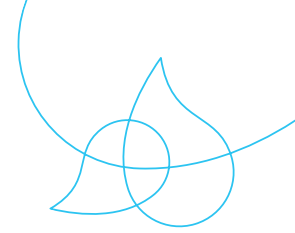

SLUICE GATE - SPS TL/RTL DN 200-630

SPS-RTL

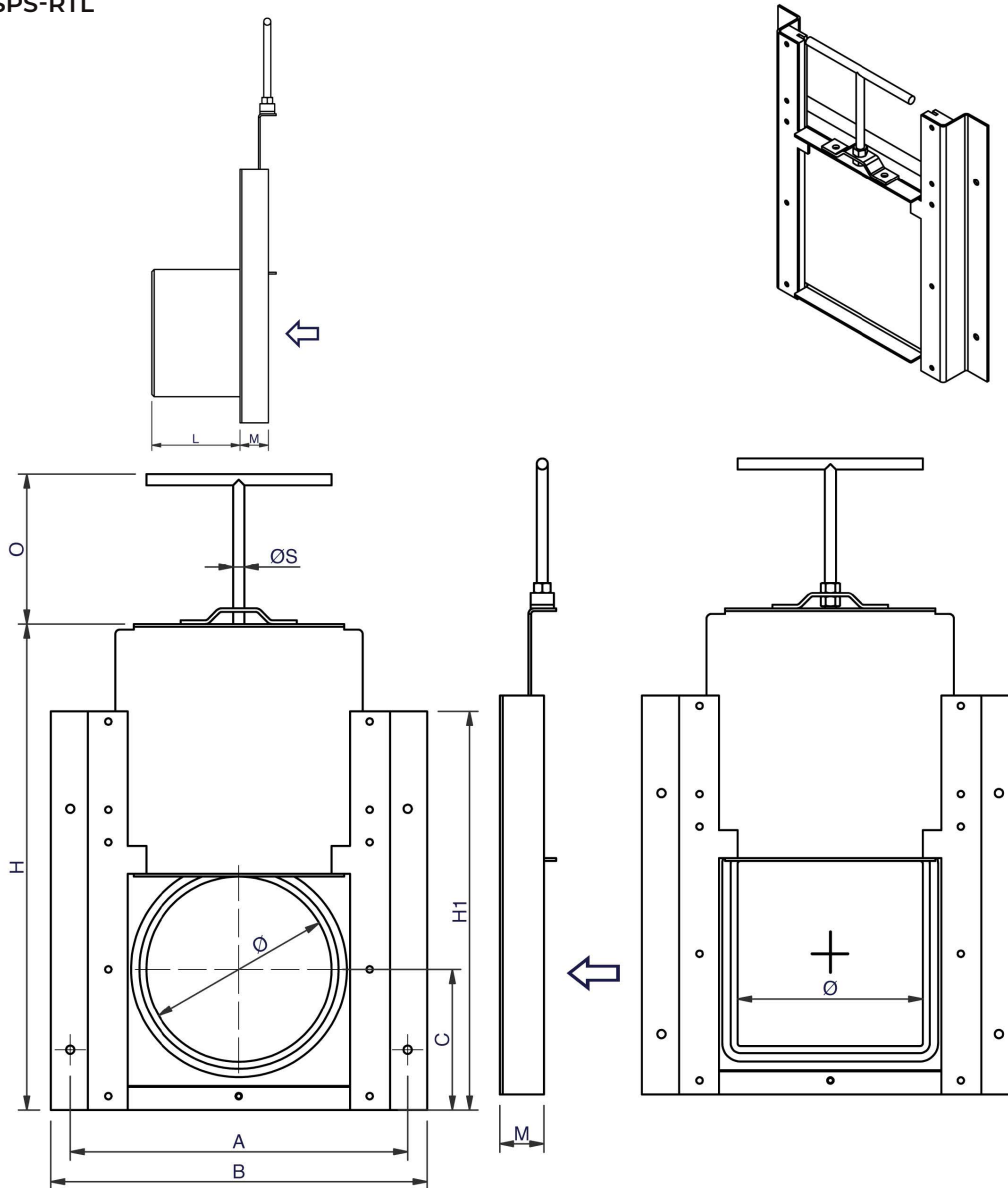

DIMENSIONER I [MM]

DN	Ø	D	A	B	C	H	H1	L	M	O	ØS	WEIGHT [KG]	MVS
200	200	200x200	364	406	152	524	434	> 175	48	150	12	8	4
250	250	250x250	414	456	177	624	484	> 200	48	150	12	10	4
300	315	315x315	479	521	210	754	550	> 250	48	150	12	12	4
400	400	400x400	564	606	252	924	634	> 300	48	200	16	16	4
500	500	500x500	664	706	302	1124	732	> 375	48	200	16	21	2
600	630	630x630	794	836	365	1384	860	> 475	48	200	16	27	2

Other dimensions on request. Reserves the right to changes.

Contact: wapro.com +46 (0)454 185 10 sales@wapro.com
 Contact GB and IE: wapro.com +44 114 308 0123 sales@wapro.com