

SLUICE GATE - SPM-S-TG DN 800-1400

AREA OF USE: Sewer and stormwater, industrial facilities and process water.
SPM-S-TG seals from both sides.

ADVANTAGES WITH WAGATE SPM-S-TG:

- No welding of the frame, thus significantly reducing corrosion degradation, therefore longer operational life
- Encapsulated bearing and sliding parts built into PEHD housing, thereby no degradation from the medium
- Easy assembly with mounting brackets locked in the frame, as well as fixed lifting brackets
- Non-rising spindle, integrated and shielded at the damper plate

OPERATION: Manually with hand wheel. Can be used with electric or hydraulic actuators.

SPECIAL DESIGN: Other pressure upon request. Spindle and nut above surface level (pedestal-mounted). Round opening.

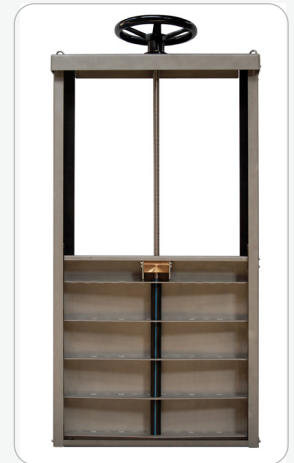

MATERIAL:

Frame	EN 1.4404 (EN 1.4462)
Damper plate	EN 1.4404 (EN 1.4462)
Spindle	EN 1.4571 (EN 1.4462)
Spindle nut	Tin bronze (Cu2Sn12)
Seal against the damper plate	EPDM
Seal against the wall	EPEM sponge rubber

TECHNICAL DATA:

Sealing according to	DIN EN 12266.1
----------------------	----------------



SLUICE GATE - SPM-S-TG DN 800-1400

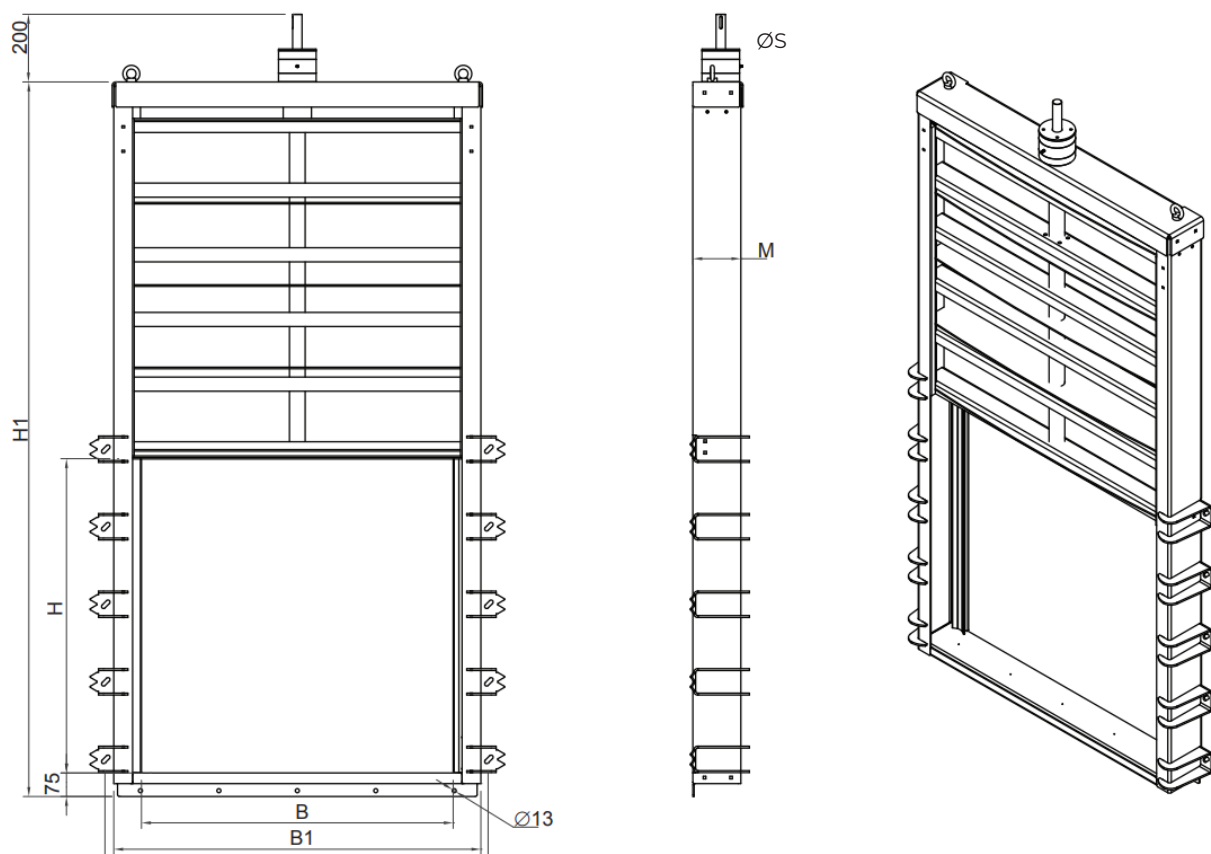

DIMENSIONS IN [MM]

DN	H	H1	B	B1	ØR	ØS	M	NM	TURNS TO OPEN	WEIGHT [KG]	MVS
800	800	1875	970	1120	19 x Ø13	25	35	35	160	155	6
1000	1000	2275	970	1320	23 x Ø13	25	65	65	167	190	6
1200	1200	2675	970	1520	25 x Ø13	30	-	90	200	270	6
1400	1400	3100	1580	1730	29 x Ø13	30	-	140	234	335	6

Other dimensions on request. Reserves the right to changes.