

© 2022 Riawatech A/S. This document is subject to copyrights owned by Riawatech A/S. Any amendments, republication, retransmission, and/or reproduction of all or any part of the document is expressly prohibited, unless the copyright owner of the material has expressly granted its prior written consent. All other rights are reserved.

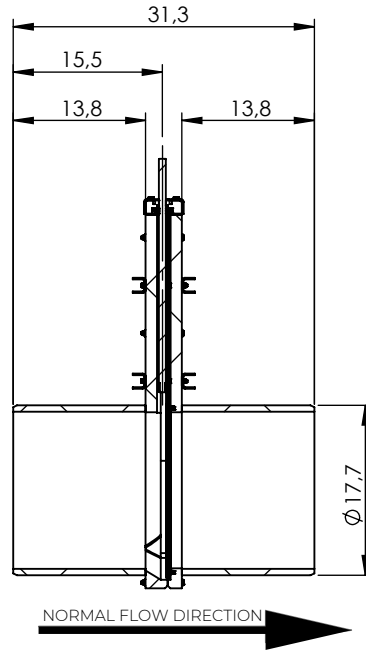
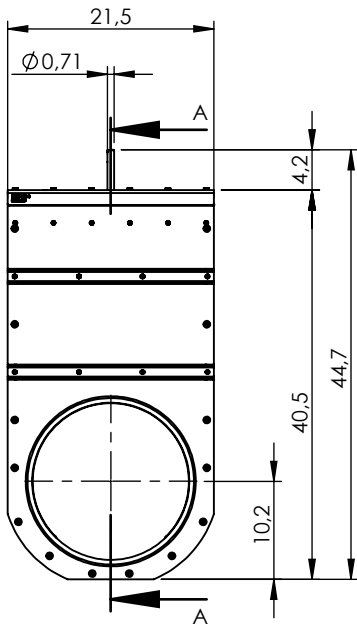
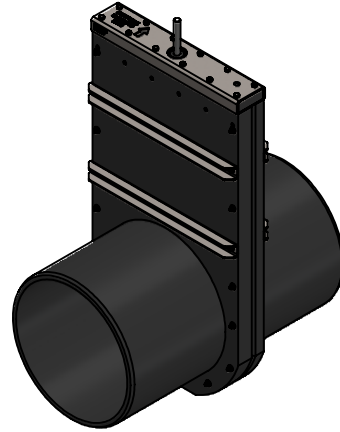
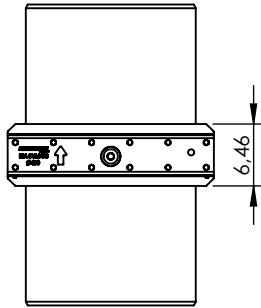

A-A

Approval Signature: _____

Date: _____

√	Article No.	Knife gate mtrl.	Spindle mtrl.	Reinforcement mtrl.
	V70076450	EN1.4404 / AISI 316	EN1.4404 / AISI 316	EN1.4404 / AISI 316
	V70078450	EN1.4462 / AISI 2205	EN1.4462 / AISI 2205	EN1.4404 / AISI 316
	V70079450	EN1.4462 / AISI 2205	EN1.4462 / AISI 2205	EN1.4462 / AISI 2205

Designed By PW	Approved By	Created Date 2022-08-29	Units [inch]	General Tolerance ISO 2768-1 m	Scale 1:20	
Material See table			Comment			
Weight [Lbs] 147,16	Box Volume [ft ³]		Description RIA Stop Valve SVM-TG NPS18			
 <small>WAPRO GROUP</small> www.riawatech.com			Article Number See table	Drawing Number svm-tg-Ø450-us	Rev A	Sheet 1 (1)